



SJ12 | SJ16

SELF PROPELLED VERTICAL MAST LIFTS

Skyjack's SJ 12 and SJ 16 self propelled vertical mast lifts provide a compact footprint and superior maneuverability. When operating in tight workspaces, a high degree steer angle allows for superior functionality and flexibility by offering zero inside turning radius. Both models feature a 0.41 m traversing platform, providing increased access and the ability to reach over potential obstacles. A unique slide away platform provides easy access to components, when raised or in the stowed position.

Skyjack's standard color coded and numbered wiring system with hard-wired relay based controls help to ensure both the SJ 12 and SJ 16 live up to Skyjack's reputation for quality and serviceability.



SKYJACK

SELF PROPELLED VERTICAL MAST LIFTS

SPECIFICATIONS

SJ12

SJ16

2006/42/CE

A Work Height	5.65 m	6.75 m
B Raised Platform Height	3.65 m	4.75 m
C Lowered Platform Height	0.45 m	0.45 m
D Overall Width	0.76 m	0.76 m
E Overall Length	1.37 m	1.37 m
E Stowed Height	1.79 m	1.79 m
G Platform Width (Inside Dimension)	0.69 m	0.69 m
H Platform Length (Outside Dimension)	0.93 m	0.93 m
Ground Clearance (Stowed)	6.35 cm	5.33 cm
Ground Clearance (Raised)	1.60 cm	1.60 cm
Wheelbase	1.05 m	1.05 m
Weight	782 kg	966 kg
Local Floor Load (With Rated Load)	696 kPa	827 kPa
Local Floor Load (No Load)	552 kPa	634 kPa
Gradeability	30 %	30%
Turning Radius (Inside)	0	0
Turning Radius (Outside)	1.40 m	1.40 m
Lift Time (With Rated Load)	16 seconds	18 seconds
Drive Speed (Stowed)	4.0 km/h	4.0 km/h
Drive Speed (Raised)	0.8 km/h	0.8 km/h
Maximum Drive Height	Full Height	Full Height
Capacity (Overall)	227 kg	227 kg
Maximum # of Persons	2	2

STANDARD FEATURES

- Drivable at full height
- Variable speed, front two wheel hydraulic drive
- Zero inside turning radius
- Dual holding brakes
- Proportional controls
- 0.41 m Traversing platform
- 24V DC power source
- Low voltage battery protection
- 30% gradeability
- Solid rubber, non-marking tyres
- Pothole protection system
- Wiring for AC outlet at platform
- 12.5 m/s (28 mph) wind rating (SJ 12 only)
- Tilt alarm with drive & lift cut-out
- Lanyard attachment points
- Operator horn
- Lift rings/tie downs
- Full height spring hinged gate
- Relay based control system
- Color coded and numbered wiring system

OPTIONS‡

- All motion audible alarm
- Dual flashing light
- AC inverter
- Saloon gate
- Light duty pipe rack/steel stud rack
- Tool tray
- Bio Oil

‡ Capacities, and machine weights may differ when options are added.

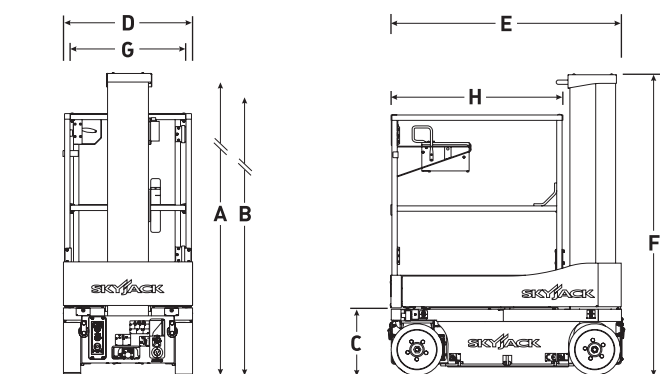

ООО "ФОРКЛИФТ"

Москва: + 7 (495) 951-79-99
 Екатеринбург: + 7 (343) 344-00-22
 Челябинск: + 7 (351) 211-54-25
 Тюмень: + 7 (3452) 38-28-26
 Пермь: + 7 (342) 294-40-49
 e-mail: sales@forklift.ru
 www.forklift.ru

This brochure is for illustrative purpose only and based on the latest information at the time of printing. Skyjack Inc. reserves the right to make changes at any time, without notice, to specifications, standard and optional equipment. Consult the Operating Maintenance and Parts Manuals for proper procedures. CE marked work platforms are in conformance to Machinery Directive 2006/42/EC.



SKYJACK™

EU/ENG/11/2012